

OWNERS MANUAL

ULTRAVIOLET DISINFECTION SYSTEM
MODEL AAGI-100-120/60 with Monitor

2008

aquaazul

MANUFACTURERS OF ULTRAVIOLET STERILIZERS

13704 HANFORD ARMONA ROAD • HANFORD, CA. 93230

P.O. BOX 337 • ARMONA, CA. 93202

Phone: 559-589-1430 • Fax: 559-589-1185

www.aquaazul.com

Installation, Operation, and Maintenance for aquaazul Ultraviolet Disinfection Systems

It is important that those responsible for installation of this equipment, as well as the owner/operator, read this manual and carefully follow the instructions and guidelines.

TABLE OF CONTENTS

1. BEFORE INSTALLATION	5
2. GENERAL INSTRUCTIONS	5
3. GENERAL MAINTENANCE	8
4. U.V. LAMP REPLACEMENT	9
5. INSTALLATION.....	9
6. WARRANTIES.....	10
7. TROUBLESHOOTING.....	11
8. SPECIFICATIONS	12
9. Wiring Diagram & Monitor Calibration Procedure.....	13 To 17

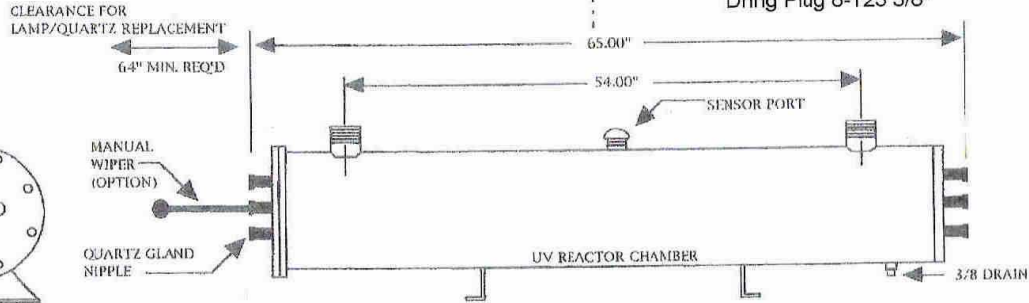
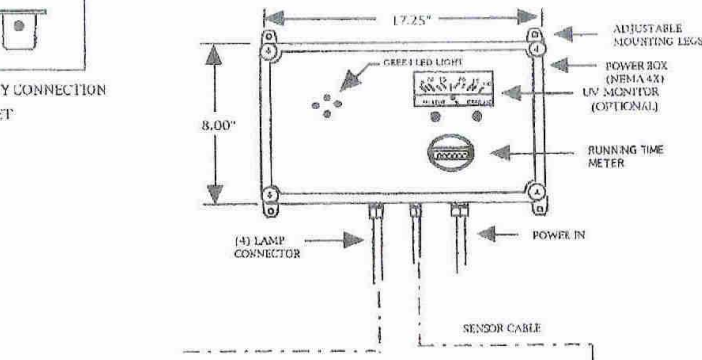
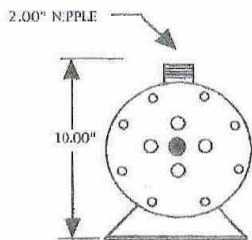
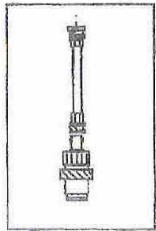
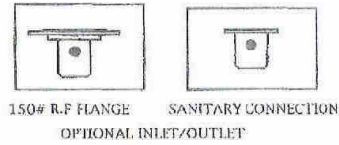

- Parts List**
- Ultraviolet Lamps L-1-804-N
 - Quartz Sleeve Q-8-257
 - Quartz Nipple 5-284-4
 - O-Rings O-8-109-A
 - SS Washer W-8-108
 - Head Gasket 5-652 5"
 - Wiper Ririns W-8-119
 - Wiper Gland 8-141
 - Wiper Gland O-Ring 8-142
 - Wiper Gland O-Ring 8-143
 - Wiper Gland O-Ring 8-144
 - Lamps Harness H-4-171-N 6"
 - U.V. Sensor S-15-216A
 - Dring Plug 8-123 3/8"

SPECIFICATIONS:

1. TYPE OF LIQUID: HIGH WATER
2. FLOW RATE: GPM (DEPENDING ON TRANSMISSION OF LIQUID)
3. PRESSURE DROP: LESS THAN 1 PSIG MAX.
4. UV DOSAGE: 90,000 MW SEC. / CM2
5. OPERATING PRESSURE: 150 PSIG MAX.
6. ELECTRICAL: 120 VAC / 60 HZ - 3.2 AMPS
220 VAC / 50 HZ - 1.7 AMPS
7. ELECTRICAL BOX IS FAN COOLED
8. LAMP TYPE: 185 NM

13704 HANFORD-ARMONA ROAD, SUITE A5 HANFORD, CA 93230	
PHONE: 559-589-1430 FAX: 559-589-1185	
MODEL: AAGI-100 TOC	MATERIAL: 304L S.S. FINISH: ELECTROPOLISHED

PLEASE RECORD THE INFORMATION PRINTED ON YOUR PURIFIER'S LABEL IN THE SPACE PROVIDED BELOW:

MODEL NUMBER: AAGI-100-120/60 with Monitor & Manual Wiper

SERIAL NUMBER:

QUARTZ SLEEVE NO: Q-8-257

ULTRAVIOLET LAMP NO: L-1-804-N

BALLAST NO: B-B-1-431-WH5-L-120

POWER IN: 120

HERTZ: 50-60Hz

DATE:

DEALERSHIP PURCHASED AT:

1. BEFORE INSTALLATION

Your Aqua Azul purifier has been thoroughly hydrostatically and electrically tested at the factory. It will give you years of trouble-free service provided these simple instructions are followed.

Check purifier and components --Each lamp and quartz jacket is wrapped and packaged separately to avoid breakage. Handle only with clean gloves.

Incoming water quality --Check the physical and chemical quality of the water to be sure transmission is acceptable for ultraviolet penetration. Each model is rated for several flow rates based on the water transmissions. A pre-filter is recommended on all water supplies.

Location of unit --The purifier should normally be installed horizontally, using the brackets provided. Clearance on the head end should be a few inches more than the overall length of the chamber. This allows room for re-lamping and removal of quartz jackets. The purifier should be located as close as possible to the point of use, or prior to all branches that need disinfecting. It should be protected from dust, heat and freezing. If an electrical plug connection is supplied, do not remove the ground prong. In wet areas, run a separate ground wire from the chamber or power supply to earth ground.

2. GENERAL INSTRUCTIONS

Read the instructions carefully --If you have any questions, consult your nearest service center or the factory. Never look at a lighted ultraviolet lamp; it can be harmful to the eyes.

Check Purifier and Components -- The inlet is normally closest to the chamber head nearest the electrical junction box. A pressure compensated flow control regulator is recommended. The flow control is installed on the outlet. If a normally closed solenoid shutoff valve is used, it is installed on the inlet of the purifier. Both the flow regulator and solenoid valve are directional; therefore, they must be positioned according to the "in" and "out" marked on the body.

Inlet and outlet manual shutoff valves should be installed, and Teflon tape should be used on all threaded connections for a good seal. Bypass around the unit is not recommended. A typical installation should be through the inlet valve, through the solenoid valve to the purifier chamber, and out through the flow control valve and outlet valve into the service line.

After the purifier has been secured and the piping connected, install the quartz jackets which are normally packed separately. Remove the quartz from the packing, using care not to get it dirty or marked with fingerprints. Unscrew the quartz nipple in the purifier head and remove the stainless steel washer and O-ring over the end of the quartz jacket approx 1/2". For purifiers with 3 ft. and 5 ft. chambers, a 3/4" diameter wooden dowel 6" to 12" longer than the quartz jacket can be a handy tool to assist as a guide in installing the quartz. (See **Figure A**). If the quartz jacket is closed at one end, wet that end first. Then slowly and carefully push the quartz straight through the head and wiper assembly (if supplied) until it sticks out approx. 5/8". Then slide on the stainless steel washer over the protruding end of the quartz jacket until it stops on the O-ring seal. (See **Figures B & C** below.)

QUARTZ FITTING ILLUSTRATION FOR JACKETS WITH ONE END OPEN AND OTHER CLOSED:

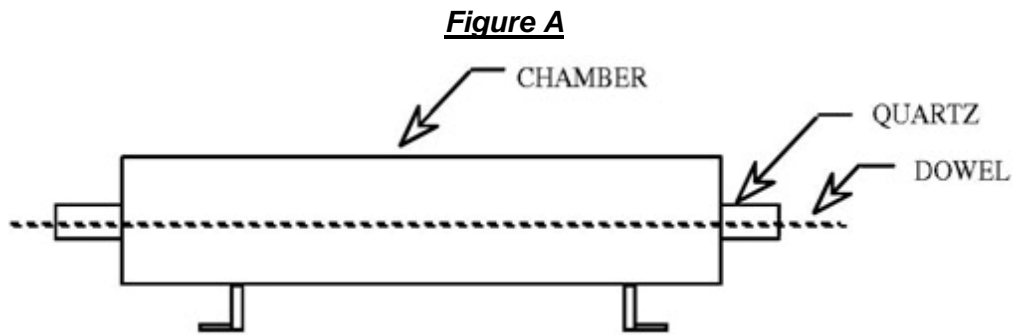
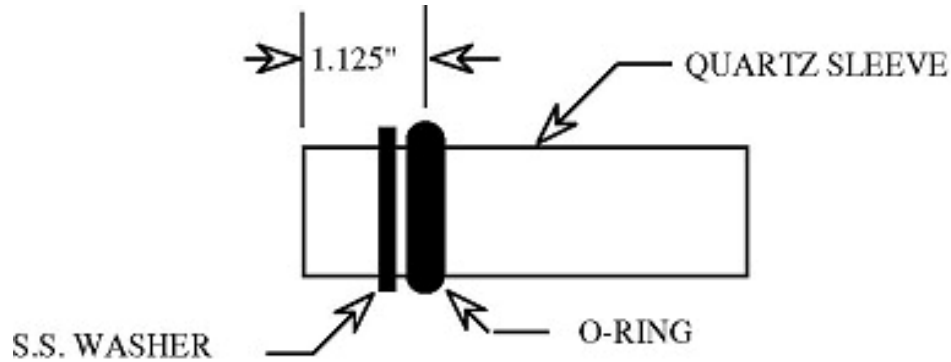
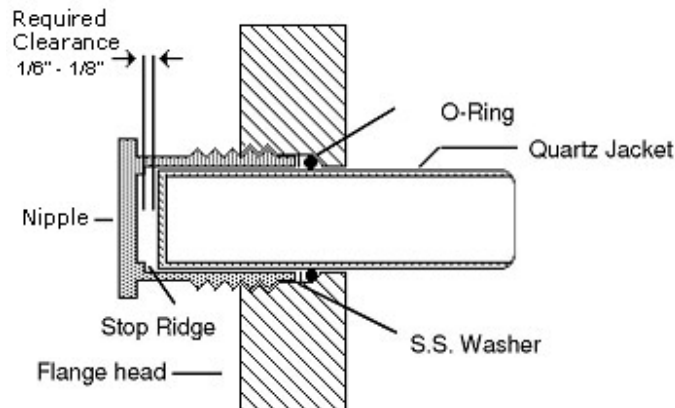

Figure B



INSTALLING QUARTZ NIPPLE OVER QUARTZ JACKET:

Figure C



Quartz jackets with both ends open disregard the 0.125 dimensions required in the illustration above. Space quartz jackets evenly between both quartz nipples at each end of the purifier head before final tightening

Be very careful when installing the quartz nipple over the quartz jacket. The quartz nipple should be assembled with care. Make sure that the end of the quartz jacket will clear the stop ridge machined into the inside of the quartz nipple. (See Quartz Fitting Illustration above.) Tighten the quartz nipple by hand. **NEVER USE PLIERS OR CHANNEL LOCKS.** The use of a tool may cause possible damage to the quartz jacket. The quartz nipple seal is designed to be tightened by hand only. Some quartz jackets have been hydrostatically tested to over 600 PSI without leaking.

To pressurize the purifier, open the outlet valve on the purifier and on spigot. Slowly open the inlet valve and flush all the air, then close the spigot. On remote power models, the inlet solenoid valve will have to be hot wired to allow solenoid to remain open.

For models with UV monitor, install the monitor sensor in the sight port located on the chamber. On remote power box models plug the monitor into the power outlet or the junction box.

Slowly pressurize the purifier, and check the quartz nipples for leaks. If there is a small leak, do not

tighten the quartz nipple if the edge of the quartz jacket is against the quartz nipple stop ridge. (See quartz fitting illustration). Depressurize the purifier and unscrew the leaking nipple. Inspect the end of the quartz jacket and the O-ring for possible damage. Then carefully reinstall the O-ring, stainless steel washer and quartz nipple, and tighten. If your purifier is supplied with quartz jackets with only one open end, then gently push the quartz jacket 1/8" to 1/4" farther into the purifier chamber. This will allow proper clearance for the quartz nipple stop ridge when reassembled into the purifier head. By hand, tighten the quartz nipple, re-pressurize the purifier and check again for leaks.

Straighten the UV lamp Wiring Harness. (See **Figure D**.) Install each UV lamp in the quartz jacket. Slide in carefully. Push on the lamp all the way in. Be sure there are no marks or fingerprints on the UV lamp. Clean with denatured alcohol and cotton, if necessary.

ULTRAVIOLET LAMP WIRING HARNESS:

Figure D

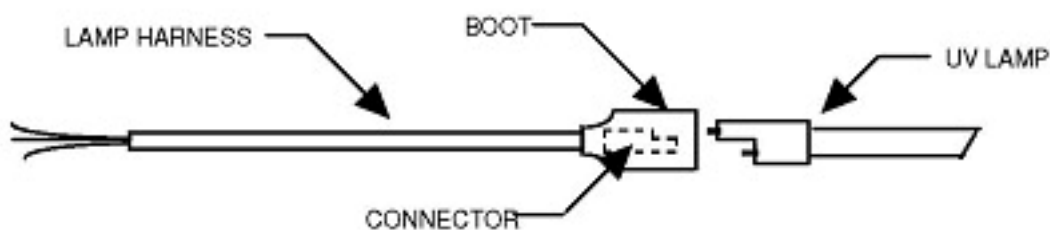

After the purifier has been pressurized and any leaks corrected, shut off the inlet valve, then outlet valve, and drain the chamber. Remove the monitor sensor and reinstall the drain plug. Fill the chamber with chlorine or other disinfectant. Reinstall the monitor in the port. Open the spigots downstream and open the outlet manual valve and then slowly open the inlet manual valve. This forces the disinfectant into the service lines. Shut off the water inlet and the spigots. Wait 30 seconds, then open and flush.

Restore the system to normal by plugging the solenoid valve cord into solenoid outlet, if provided. (On remote power boxes, rewire according to print.) Your purifier is now complete and ready for operation.

Reconnect power to the UV monitor and turn on the system.

If the UV energy dosage, as measured by the monitor, falls below the U.S. Department of Health Standard, the solenoid valve will close, and UV monitors with audible alarm will sound. No impure water can enter the service line when the monitor is in the failure mode, See Table II, Troubleshooting Guide.

Complete the Warranty Registration Card and mail to the factory.

Keep the quartz jacket(s) clean --If the quartz jacket becomes coated, the bacteria-killing strength of the ultraviolet lamps are reduced and the purifier will have to be disassembled and the quartz jacket(s) cleaned by hand.

3. GENERAL MAINTENANCE

If your purifier is equipped with a **Manual Wiper System**, the wiper should be operated regularly to keep the Quartz Sleeve clean and the ultraviolet intensity at its peak. The quality of the water flowing through the purifier will determine the frequency at which the Manual Wiper System should be operated. Weekly cleaning may be sufficient for most potable water, but color turbidity and iron are factors in some water supplies. In this situation, daily cleaning may be necessary.

MANUAL WIPER ASSEMBLY:

Figure E



Models with Fully Automatic Wiper Systems have a pressure-driven hydraulic cylinder installed, which drives the Quartz Sleeve Wiper Assembly (50 PSI to 100 PSI air pressure). The timer is pre-set at the factory, normally for the 12-hour cycle; however, it can also be factory-set for either the 6-hour or the 3-hour cycle for water or other liquids with low transmission. (Consult the factory for further details.)

A hose should be run to a floor drain for cylinder exhaust if water is used to pressure the hydraulic cylinder. Connect the four-way solenoid valve, with ¼" copper tubing, to a pressure source of 75 PSI minimum. Connect the wiper feed line upstream from purifier inlet. (**Note:** If water is used, a pre-filter should be installed on the cylinder feed water line.)

Figure F

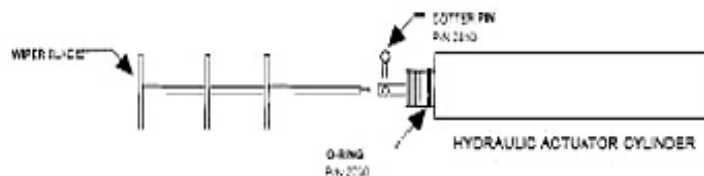

4. U.V. LAMP REPLACEMENT

The U.V. lamps are rated for 13,000 to 15,000 hours of continuous use. After this period of time, the U.V. lamp's glass envelope has undergone a photo-chemical change, and, while the lamp may not have burned out, the envelope will no longer pass the amount of U.V. energy required to destroy bacteria. **Failure to replace U.V. lamps every 15,000 hours could cause the equipment to go into performance failure!**

UNDER NO CIRCUMSTANCES SHOULD A U.V. LAMP BE USED OR STORED FOR MORE THAN 24 MONTHS. (Normal shelf life is 24 months).

The use of clean cotton gloves is recommended when handling Quartz and Lamps. Be very careful when handling the Quartz Sleeve and Lamps as they are extremely fragile.

Replace ultraviolet lamps after 10 to 12 months of continuous use, or when the monitor reads 70% of new lamp output. You should not wait for the monitor to cut off. Always stock spare Ultraviolet Lamps and Quartz Sleeves.

Disinfect the entire system after shutdown or service.

If equipped, operate the Quartz Sleeve Wiper Systems regularly on manual modes (push /pull stroke). You cannot over-clean the Quartz Sleeve.

Keep a record of ultraviolet intensity readings, ultraviolet lamp replacement dates and service dates.

Test the water quality periodically Collect samples in sterile bottles, listing the time and date the sample was drawn on the bottle's label. Send to the nearest testing laboratory of your local health department. In most areas the local department will collect and test your water for purity at no charge.

During Ultraviolet Lamp replacement, clean the inside and outside of the Quartz Sleeves with denatured alcohol. Clean and polish the lens on the Fail-safe Monitor Sensor. If purifier is supplied with a Wiper Cleaning System, replace the Wiper Rings (Part No. W-8-119), and Quartz O-Rings (Part No. 8-109A). When ordering parts always give the Part Number, Serial Number, and Voltage / Cycle Input (120/60).

5. INSTALLATION

Installation for swimming pools and hot tubs

Install the purifier in series with return line after the filter, but before the heater, if one is used.

Note: Flow control is used as each purifier is sized for your pump flow. Do not install a purifier with a smaller opening than the pump discharge, as the flow will be restricted.

The water should be re-circulated through the purifier 24 hours per day. A small residual of 0.25 parts per million (ppm) of chlorine may be required. The 1ppm or 2ppm chlorine residual normally required can be reduced up to 75%, depending on the weather, the size of the pump, and the filter.

For optimum swimming conditions, the recommended turnover time is every six (6) hours.

Longer turnover time may require higher chlorine residuals for algae control.

The entire pool and hot tub area, -water walk area, pump filter, lines-should be purged with a 12 ppm residual of chlorine at start-up to eliminate algae spores and other Microorganisms.

Purifier Maintenance in pools and Hot tubs

The Maintenance is the same as that of standard purifier. In the wintertime, when temperature is at the freezing point, the purifier should be drained and the lamps and Quartz Sleeves should be removed from the purifier and stored in a clean, dry area.

On start-up follow the standard installation procedure.

6. WARRANTIES

GENERAL LIMITED WARRANTY

Aqua Azul warrants products manufactured against defects in materials and workmanship when used in accordance with applicable instructions for a period of one year from the date of product shipment where applicable or from an Aqua Azul approved period of time. Aqua Azul makes no other warranty, expressed or implied. There is no warranty or merchantability or fitness for a particular purpose. The warranty provided herein, and the data, specifications, and descriptions of Aqua Azul's published catalogues and product literature may not be altered except by express written agreement signed by an officer of Aqua Azul. Representations, oral or written, which are inconsistent with said warranties or such publications are not authorized, and, if given is not the responsibility of Aqua Azul.

In the event of a breach of the foregoing warranty, Aqua Azul's sole obligation shall be to repair or replace, at its discretion, any product or part thereof that proves defective in materials or workmanship within the warranty period, provided that the customer notifies Aqua Azul promptly of any defect. Aqua Azul shall not be liable for consequential damages resulting from economic loss or property damages sustained by a customer from the use of its products.

LAMP WARRANTY

Aqua Azul warrants the Ultraviolet lamps on a pro-rated formula. Mercury vapor UV lamps supplied by Aqua Azul --either with the original equipment or as replacement lamps – found to be faulty, shall be replaced as follows:

Units installed for continuous operation:

Less than 1500 hours of operation.....	Lamp replaced at no charge
More than 1500 and less than 4000 hours of operation	Lamp replaced at 50% of charge
More than 4000 and less than 6000 hours of operation	Lamp replaced at 75% of charge
More than 6000 and less than 8000 hours of operation	Lamp replaced at 80% of charge
More than 8000 hours of operation	Lamp replaced at full charge

Units installed for intermittent operation:

In any installation where more than 6 strikes are experienced in any 24 hour period, faulty or failed lamps will be replaced by Aqua Azul—at no charge—where failure occurs within the first 100 hours of

operation..

TROUBLESHOOTING GUIDE		
PROBLEM	CAUSE	CORRECTION
UV LAMPS WON'T LIGHT	INCORRECT VOLTAGE	INSTALL A VOLTAGE REGULATOR
	DISCONNECTED OR DEFECTIVE OUTLET	CHECK AND REPLACE
	DEFECTIVE UV LAMP	REPLACE LAMP
	DEFECTIVE LAMP BALLAST * Check output. Must be 480V - 580V across lamp connections	REPLACE BALLAST
	BLOWN FUSE	REPLACE FUSE
	LOOSE OPEN-CIRCUIT WIRE	TRACE OUT AND REPAIR
LEAK AT QUARTZ NIPPLE	DEFECTIVE OR CRACKED O-RING	REPLACE
	O-RING NOT SEATED PROPERLY	REPLACE
	QUARTZ SLEEVE CRACKED	REPLACE
LOW UV READING OR WATER SHUTOFF	POOR TRANSMISSION * Check output of lamps by emptying liquid from chamber. Clean quartz, monitor, sensor, and lens. Turn on lamps in empty purifier and check reading. EXAMPLE: READING IN WATER = 12 READING IN AIR = 42 TRANSMISSION = $12/42 \times 100 @ 28\%$	ENSURE LAMPS DO NOT NEED REPLACEMENT. (See 4: UV Lamp Replacement) INSTALL PREFILTER AND TEST * Less than 60% considered poor transmission.
	INPUT VOLTAGE LOW	INSTALL VOLTAGE REGULATOR
	OLD OR DEFECTIVE LAMP	REPLACE
	DIRTY LAMP OR QUARTZ	REMOVE AND CLEAN CAREFULLY
	DIRTY SENSOR LENS	REMOVE AND CLEAN
	WIPER RINGS WORN OUT OR NOT OPERATED OFTEN ENOUGH	REPLACE AND INCREASE FREQUENCY OF OPERATION

POOR QUALITY WATER UNDER 0.2 ABSORPTION COEFFICIENT (60%), WILL RESULT IN A LOWER PERCENTAGE OF TRANSMISSION OF ULTRAVIOLET AND MUST BE CORRECTED BY PROPER PRETREATMENTS. INTERFERING FACTORS SUCH AS COLOR, TURBIDITY, IRON, ORGANICS, CHLORINE, OR NITRATES IN HIGH LEVELS WILL CAUSE LOW UV MONITOR READINGS. IF THE PERCENTAGE OF TRANSMISSION IS NOT INCREASED BY PROPER PRETREATMENT, THE FLOW THROUGH THE PURIFIER MUST BE REDUCED FOR LONGER UV TIME.

FINAL NOTE: WHEN THE PURIFIER IS ON, ENSURE THAT WATER IS ALWAYS FLOWING THROUGH IT. OPERATING THE PURIFIER FOR EXTENDED PERIODS OF TIME WITHOUT WATER FLOW WILL OVERHEAT THE PURIFIER AND DECREASE THE GERMICIDAL RADIATION EFFICIENCY OF THE LAMPS. IT MAY ALSO DAMAGE OTHER ELECTRICAL COMPONENTS.

SPECIFICATIONS

Model Number: AAGI-100-120/60 With Monitor

Flow rate capacity:

Waste Water: 90 GPM
Fresh Water: 100 GPM (Depending On Transmission Of Liquid)
High Purity:

Number of Lamps: 4

Inlet/Outlet Size: 2" Nipple Inlet & Outlet

Material: 304 SS

Voltage/Cycle Input: 120V / 50-60Hz

kW:
Amps: 1.70

Dimensions:

Length: 65"
Width: 8"
Height: 14"

Shipping Weight:

Accessories: Manual Wiper
Auto Wiper
Remote Alarm
Inlet Solenoid
UV.MONITOR

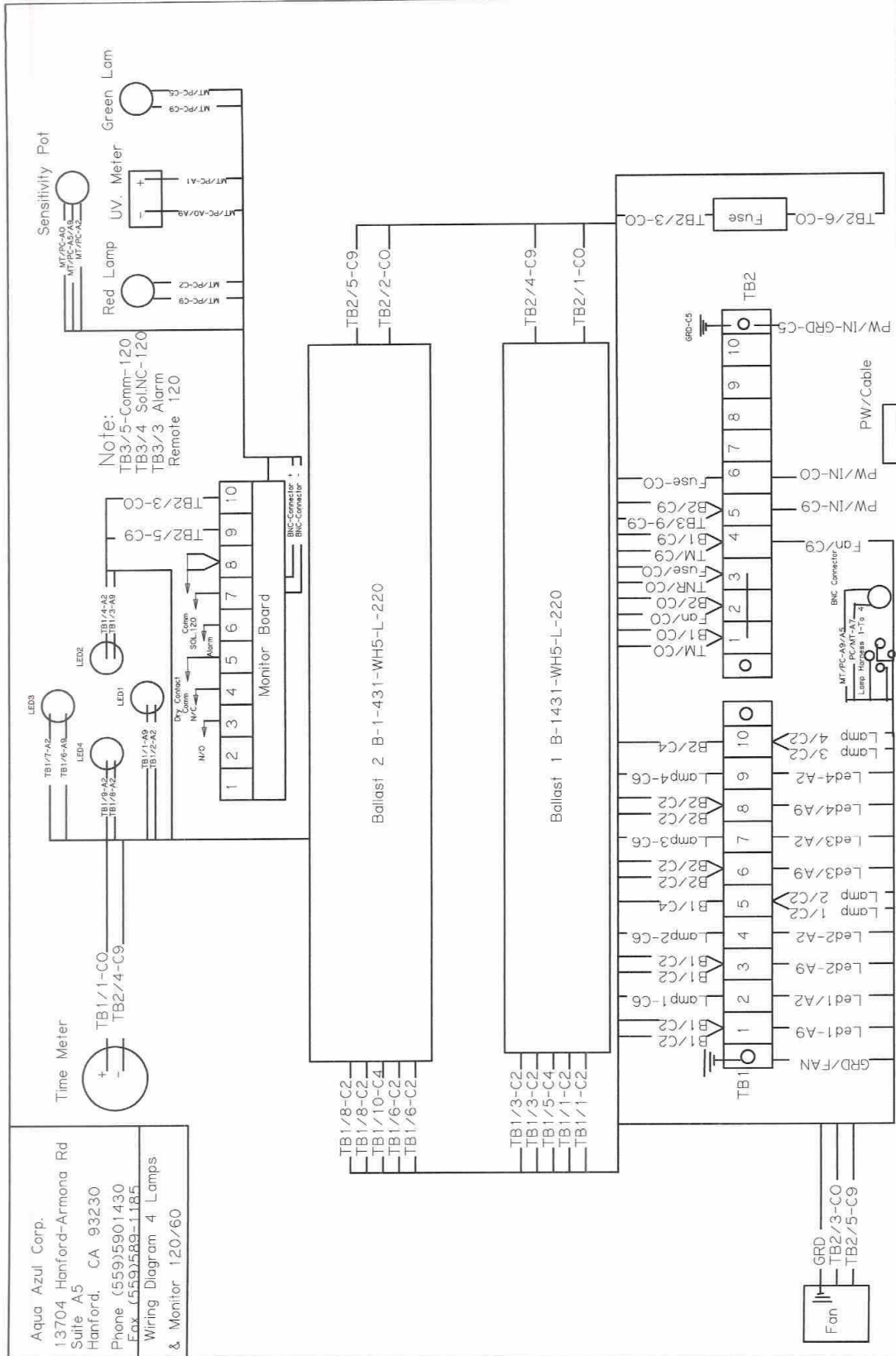

The remote GL - 100 UV Monitor consists of a stainless steel sensor probe, coax cable and a meter box. The GL - 100 is designed to operate independently of the ultraviolet water purifier.

The GL - 100 Monitor measures the intensity of the germicidal portion of the irradiation from the UV lamp(s) at the chamber wall. The sensor contains a narrow band response phototube. The monitor converts the signal from the sensor to a meaningful display of the panel meter.

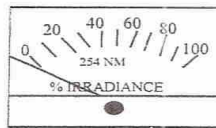

The monitor allows you to know how effective the disinfection is by a relative indication of UV irradiation. The "Relative % Irradiation" reading is effected by the following parameters:

- Lamp degradation (age & temperature)
- Water turbidity
- Clarity of the quartz sleeve(s)
- Clarity of the sensor window

Properly setup, the monitor indicates the percent of UV necessary for the kill rate this purifier was specified to accomplish for your water conditions. The nominal (specified) conditions are associated with "100%". Deviations will be reflected accordingly by the panel meter and indicator light(s). The **GREEN** indicator lights for illumination levels within allowable design tolerances. As parameter values change and conditions degrade below "60%" the alarm will activate and the **RED** indicator lights. The alarm will deactivate if conditions improve a certain amount, 1-5% of F.S. (full scale), above the "Alarm" threshold.

CALIBRATION PROCEDURE

The monitor is tested and calibrated in air at the factory. Field calibration of your monitor at initial setup fixes the "100%" point to coincide with the values of the above parameters, as well as the geometry of your purifier.

The calibration procedure is performed during operation of the fully installed purifier (the sensor in place, all electrical power on and water flowing). The nominal quality and temperature of the flowing water should be stable.

Adjustments will be made at 2 times in the early life of the UV lamps:
-5 minutes (or more) after power on to allow for lamp warm-up.
-100 hours of UV lamp use.

Re-calibration of the monitor is recommended, after the initial setup described below, for any of these reasons:

1. New lamps are installed.
2. A substantial change in inlet water quality or water temperature occurs.
3. Sensor or monitor components are changed. The factory will recommend a setting based on the age of the system.

"sensitivity"

GL - 100 UV MONITOR

AFTER 5 MINUTES OF WARM-UP AND FLUID FLOWING:

Alarm Threshold setting:

- This may have been done at the factory, but should be repeated for your assurance.
- Adjust the "Sensitivity" pot so the meter indicates 60%.
- Adjust the "Alarm" pot CW (clockwise) if the GREEN indicator lamp is ON (lit), until the

RED indicator in ON.

- Set the "Alarm" pot at the point where the RED indicator turns OFF and GREEN turns ON as it is turned CCW (counter-clockwise). If you pass this "point", turn back a little** and repeat.

Sensitivity setting:

- Adjust the "Sensitivity" pot so the meter indicates 100%.

AFTER 100 HOURS OF NEW LAMP OPERATION:

The normal early decay period has elapsed and a stable emittance level is achieved for the next 1900 hours. The quartz jacket(s) should be wiped with the wiping system, if so equipped.

Alarm Threshold setting:

- Perform procedure as in the "5 minute warm-up" for assurance, but is not expected to drift.

Sensitivity setting:

- Adjust the "Sensitivity" pot so the meter indicates 100%.

SPECIFICATIONS:

INPUTS:

- Power: 120VAC, 1.5A fuse, 1.2VA without switched-power load, 60HZ, 1-phase.
- UV Sensor: Narrow band 185 - 320 nm response.

OUTPUTS:

- Panel Meter indicates 0-100% irradiance relative to purifier design specifications.
- RED light comes ON when in alarm state. The monitor may be in alarm until UV lamp warms up.
- GREEN light comes ON during normal operation.
- Relay switched-power contacts supply 1A @ 115VAC, via 1-1/2 Amp fuse on cabinet.
- The "alarm" receptacle is energized during the alarm state (coincides with de-energized relay, RED indicator). The water shut-off "solenoid" receptacle is energized (to keep valve open) during the normal GREEN (non-alarm) state.

ALARM THRESHOLD CONTROL:

Field adjustable in the range 0 - 100% via multi-turn pot. Aqua Azul modification: hysteresis of 1 - 5% full scale to prevent relay chatter, burn-out and spurious alarms.

SENSITIVITY CONTROL:

Field adjustable in the range 0 - 100% via multi-turn pot.

NOTE: Both "Alarm" and Sensitivity" controls are multi-turn potentiometers. Turning clockwise CW has an increasing effect on the meter indication (turn counter-clockwise CCW to decrease).

There is a "deadband" built into the Aqua Azul's UV monitors that require a number of turns to get past.

GL - 100 MONITOR BOARD

SUMMARY OF KEY POINTS:

- Power: 120VAC / 60HZ.
- UV Sensor: Narrow band response phototube (254 NM).
- Panel meter indicates 0 - 100% irradiance relative to purifier design specifications.
- Red light comes on when in alarm state.
- The monitor may be in alarm state until UV lamp(s) warms-up.
- Green light comes on during normal conditions.
- Normal warm-up 5 minutes.
- Re-calibrate after 100 operating hours of new lamp.
- Verify that the power to the monitor is on.
- Verify that the sensor cable is connected to the meter.
- Verify that the monitor switch is in the on position.

TROUBLE SHOOTING GUIDE

- | | |
|---|---------------------------------------|
| 1. Dirty quartz jacket | 1. Remove and clean |
| 2. Old or broken quartz jacket | 2. Replace |
| 3. Old UV lamp(s) | 3. Replace |
| 4. Low voltage output | 4. Install regulator |
| 5. Defective Ballast | 5. Replace |
| 6. Dirty, cloudy, or high mineral content | 6. Install prefilter or demineralizer |
| 7. Dirty sensor lens | 7. Remove and clean |
| 8. Water or condensation inside quartz | 8. Remove and dry internal quartz |
| 9. Water or condensation inside sensor | 9. Remove and dirt internal sens |